

APPROVALS



ENGINEERING CODE
212AN06

APPROVED REFRIGERANT
R-134a

POWER SUPPLY
200-240 V 50 Hz

STANDARD CONDITIONS
ASHRAE

APPLICATION
HBP

COOLING CAPACITY
1602 W (HBP)

EFFICIENCY
2.51 W/W (HBP)

MOTOR TYPE
CSIR

STARTING TORQUE
HST

DATA

General Data

Type	Hermetic reciprocating
Technology Type	On-Off
Displacement	17.39 cm ³
Compressor Cooling	Fan/NotControlled/200
Fan Air Flow	520 m ³ /h
Expansion Device	Capillary Tube or Expansion Valve
Horse Power	1/2 hp
Max Condensing Pressure Operating	13.92 bar
Max Condensing Pressure Peak	15.62 bar
Power Supply	200-240 V 50 Hz / 230 V 60 Hz
Evaporating Temperature Range	-15 °C to 10 °C

Electrical Data

Motor type	CSIR
Starting Torque	HST
Start Winding Resistance	13.8 Ω at 25° C
Run Winding Resistance	2.7 Ω at 25° C

Mechanical Data

Maximum Recommended Refrigerant Charge	800 g
Oil Charge	450 ml
Oil Type Configuration	ESTER
Oil Type Viscosity	ISO22
Pressurization	Dry air charge
Weight	17 Kg
Free Internal Volume	3.3 L

Electrical Components

	Description
Start Capacitor	64-77 Uf / 330 V
Starting Device	Relay MTRP-46*
Motor Protection	T0540/G8

External Characteristics

Base Plate	Universal	
Tray Holder	No	
Height	220 mm	
Connector	Internal Diameter	Shape
Suction	9.6 mm	Slanted 42°/Copper
Discharge	6.42 mm	Straight/Copper
Process	6.42 mm	Vertical/Copper

PERFORMANCE

Rated Points

Condensing Temperature	Evaporating Temperature	Cooling Capacity	Power Consumption	Current	Gas Flow Rate	Efficiency
54.40°C	7.20°C	1602 W	639 W	3.91 A	35.48 kg/h	2.51 W/W

Test Condition: ASHRAEHBP46, Fan/NotControlled/200, Return Gas 35°C, Evaporation 7.20°C, Condensing 54.40°C, Ambient 35°C, Liquid 46.1°C, Subcooling 8.3K. Data in accordance to EN

12900:2013 and AHRI 540:2015 polynomial equation and uncertainty guidance.

Performance Curve Data

Condensing Temperature 35°C

Evaporating Temperature °C	Cooling Capacity W	Power W	Current A	Gas Flow Rate kg/h	Efficiency W/W
-15	770	346	2.73	14.21	2.23
-10	995	382	2.86	18.42	2.61
-5	1264	415	2.98	23.49	3.05
0	1576	447	3.11	29.43	3.53
5	1933	478	3.23	36.28	4.05
10	2333	508	3.36	44.06	4.6

Test Condition: ASHRAEHBP46, Fan/NotControlled/200, Return Gas 35°C, Ambient 35°C, Subcooling 8.3K. Data in accordance to EN 12900:2013 and AHRI 540:2015 polynomial equation and uncertainty guidance.

Condensing Temperature 45°C

Evaporating Temperature °C	Cooling Capacity W	Power W	Current A	Gas Flow Rate kg/h	Efficiency W/W
-15	661	365	2.8	13.18	1.81
-10	859	411	2.97	17.19	2.09
-5	1097	457	3.14	22.04	2.4
0	1376	503	3.33	27.78	2.73
5	1696	551	3.52	34.43	3.08
10	2055	599	3.72	42.02	3.43

Test Condition: ASHRAEHBP46, Fan/NotControlled/200, Return Gas 35°C, Ambient 35°C, Subcooling 8.3K. Data in accordance to EN 12900:2013 and AHRI 540:2015 polynomial equation and uncertainty guidance.

Condensing Temperature 55°C

Evaporating Temperature °C	Cooling Capacity W	Power W	Current A	Gas Flow Rate kg/h	Efficiency W/W
-10	724	442	3.08	15.79	1.64
-5	930	497	3.31	20.38	1.87
0	1173	554	3.55	25.86	2.12
5	1454	614	3.81	32.25	2.37
10	1772	676	4.08	39.59	2.62

Test Condition: ASHRAEHBP46, Fan/NotControlled/200, Return Gas 35°C, Ambient 35°C, Subcooling 8.3K. Data in accordance to EN 12900:2013 and AHRI 540:2015 polynomial equation and uncertainty guidance.

Operating Envelope

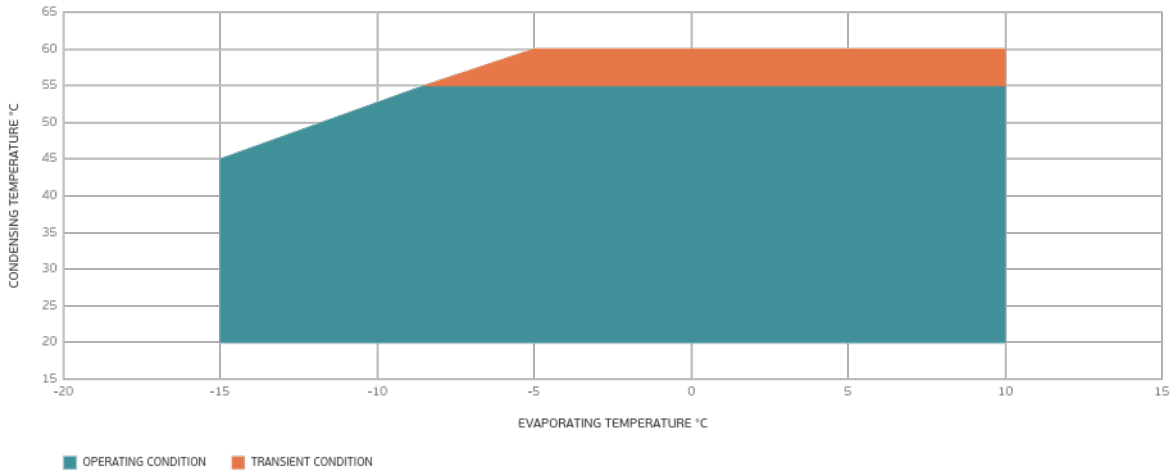

External Dimensions

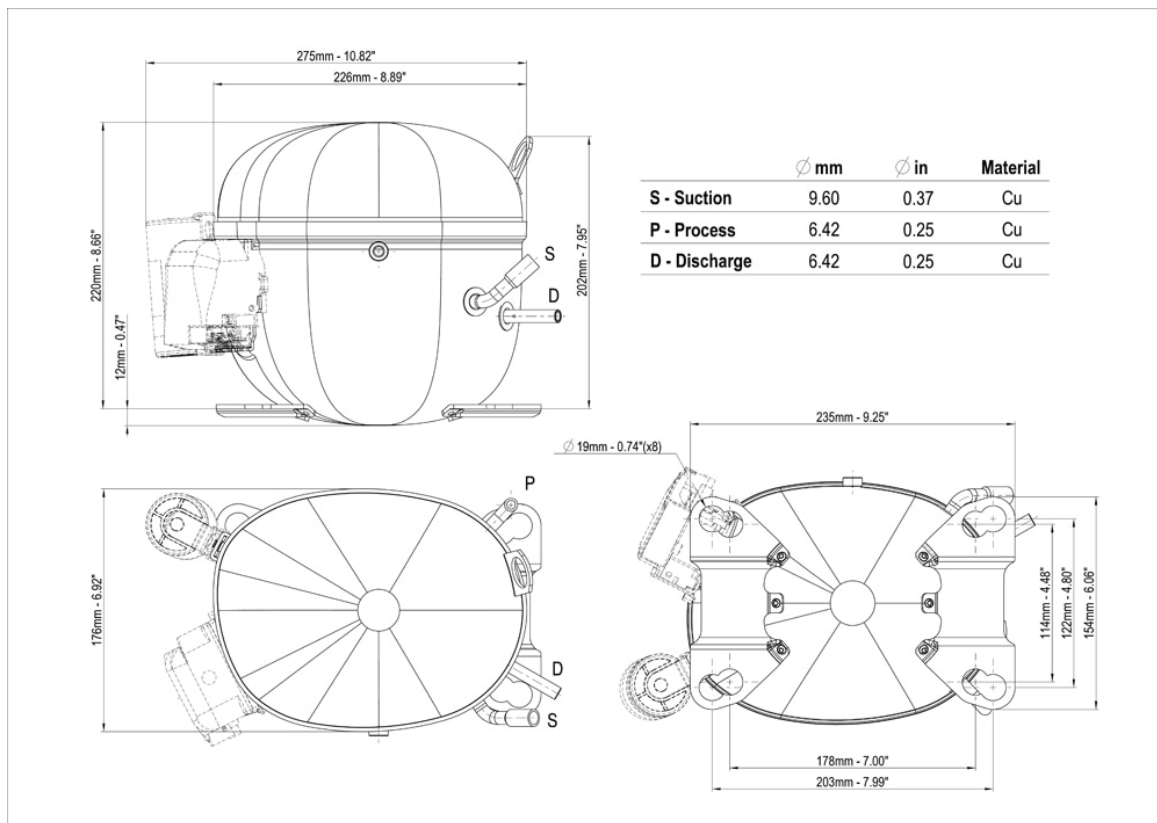

Wiring Diagram



Assembly Instructions

